



Accelerometer Modules

SAA: 1-Axis

DAA: 2-Axis

TAA: 3-Axis

for

Dynamic Acceleration Measurement

The CORRSYS-DATRON Low-G accelerometer modules provide a complete low-g acceleration measurement solution in a single, compact package.

Utilizing a measurement structure micro-machined in silicon, the CORRSYS-DATRON Accelerometer Modules are robust enough to withstand the punishment of harsh industrial and automotive environments. The measurement signal is generated via a change in the capacitive property of the structure, caused by a change in velocity, i.e. acceleration, and converted into an electrical signal which is amplified, filtered, and voltage-compensated, resulting in a highly accurate and linear measurement.

Features

- Integrated 1-, 2- or 3-axis measurement
- Dynamic ranges from $\pm 1g$ to $\pm 100g$ upon request
- Frequency response up to 4,000 Hz upon request
- 6 ... 42V single supply operation
- Temperature range: -40°C ... $+85^{\circ}\text{C}$

Applications

- Measurements of lateral & longitudinal acceleration
- Ride comfort measurements
- Position & motion sensing
- Tilt sensing
- Vibration analysis
- Crash sensing



Art. No.:

SAA, 1-axis

15760

DAA, 2-axis

15951

TAA, 3-axis

15911

Typical Technical Data

Specifications:

Parameter	Nominal Value	Tolerance
Full Scale Sensitivity	±3 G; 666 mV/G	±1% FS
Zero G Bias Output	+2.5 V DC	±100 mV
Full Scale Span	±2.0 V DC	±1% FS
Frequency Response	DC to 5 Hz, -3dB	±10%
RMS Equivalent Noise	560 µG RMS Gaussian	±15%
Nonlinearity	±0.2%	
Alignment	±2 °	
Transverse Sensitivity	±2% FS span (max.)	
Zero Rate Bias Drift	0.2 G max. -40°C to 85°C Span	
Temperature Range	-40°C to 85°C (operating) -65°C to 125°C (storage)	
Supply Voltage	+6 to +42 V DC	
Supply Current	<10 mA per axis (no load)	
Shock	500 G (powered) 1000 G (unpowered)	
Mass	45 g	±10 g
Packaging	Anodized 6061 Aluminium; Epoxy Potting Shore 85D Hardness	

Additional ranges and corner frequencies available.

Pin Assignment:

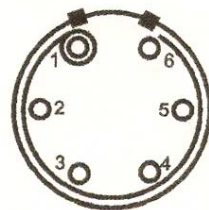

LEMO EGA.1B.306

- 1 DC Power supply
- 2 Output A3 axis (TAA)
- 3 Signal GND
- 4 Output A2 axis (DAA and TAA)
- 5 Output A1 axis
- 6 DC GND

Dimensions:

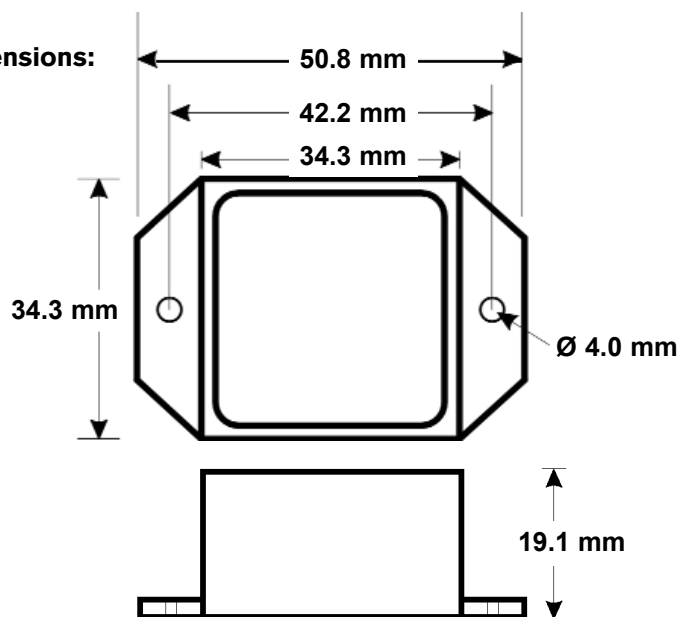

© 2009 CORRSYS-DATRON Sensorsysteme GmbH, Germany
Accelerometer Modules_d-013-e-rev002 08/09

CORRSYS-DATRON
A Kistler Group Company

CORRSYS-DATRON Sensorsysteme GmbH
P.O. Box 1349 • 35523 Wetzlar / Germany
Phone: +49 64 41 92 82 0
Fax: +49 64 41 92 82 17

www.corrsys-datron.com

sales@corrsys-datron.com

KISTLER
measure. analyze. innovate.

www.kistler.com



Attention:

The new CDS Accelerometer Modules are equipped with a connector that is different from the former +5V Accelerometers (SAA, DAA, TAA) and cannot be used with the cables delivered with these +5V sensor types.

In a continuous effort to improve our products, CORRSYS-DATRON reserves the right to change specifications without prior notice.

Kistler Instrumente AG
P.O. Box • CH-8408 Winterthur / Switzerland
Phone: +41 52 224 11 1
Fax +41 52 224 14 14

info@kistler.com