

CORRSYS

DATRON

Sensorsysteme GmbH

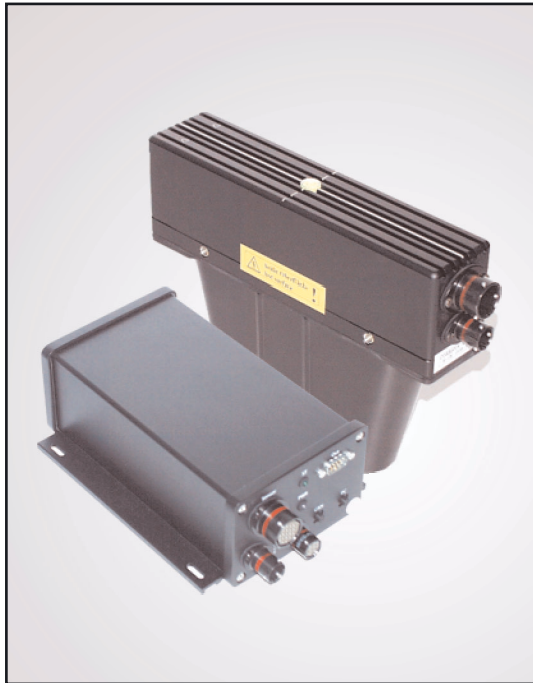
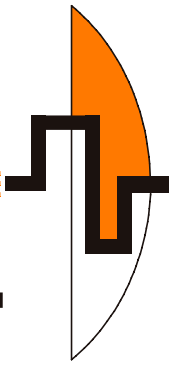

CORREVIT[®] H-CE[™]

Non-Contact
Optical Sensor

for

*slip-free measurement
of vehicle ride height*

USER MANUAL

Notes:

Table of Contents

General Information	4
Safety Instructions	5
1. Overview	6
2. Extend of Delivery	8
3. Technical Data	9
3.1 Specifications	9
3.2 Pin Assignments	9
3.2.1 Electronic Out	9
3.2.3 Can Bus Output	10
3.2.4 PC (RS232) Output	10
3.2.4 Power Connectors	10
3.3 Default Settings	11
3.4 Internal Signal Filtering	11
3.5 Typical Data Plot	11
4. Set-up and Connection	12
4.1 Mounting Options	12
4.2 Sensor Orientation	12
4.3 Sensor Mounting Jig	13
4.4 Connecting the Sensor	13
5. Troubleshooting	15

Appendix: - Technical Drawings

CORREVIT® is a registered trademark of CORRSYS-DATRON Sensorsysteme GmbH, Wetzlar Germany. In a continuous effort to improve our products CORRSYS-DATRON reserves the right to change specifications without prior notice.

General Information

Legal Notice

Information furnished is believed to be accurate and reliable. However, CORRSYS-DATRON assumes no responsibility for the consequences of use of such information nor for any infringement of patents or other rights of third parties which may result from its use. No license is granted by implication or otherwise under any patent or patent rights of CORRSYS-DATRON. Specifications mentioned in this publication are subject to change without notice and do not represent a commitment on the part of CORRSYS-DATRON. This publication supersedes and replaces all information previously supplied.

All brand names are trademarks of their respective holders.

Copyright Notice

©Copyright 2003, CORRSYS-DATRON

Revision

D008-50-02-04E 11/04

Contact

International Headquarters:

CORRSYS-DATRON Sensorsysteme GmbH

Charlotte-Bamberg-Str. 12

35523 Wetzlar / Germany

Phone ++49 (6441) 9282-0

Hotline ++49 (6441) 92 82 82

Fax ++49 (6441) 9282-17

E-mail sales@corrsys-datron.com

URL www.corrsys-datron.com

North American Headquarters:

CORRSYS-DATRON Sensorsystems, Inc.

21654 Melrose Avenue, Building 16

Southfield, MI 48075 / USA

Phone ++1 (248) 204-0850

Toll-free ++1 (800) 832-0732

Fax ++1 (248) 204-0864

E-mail USA-sales@corrsys-datron.com

URL www.corrsys-datron.com

Safety Instructions

Please read carefully before operating the equipment.

CORRSYS-DATRON is not responsible for damage that may occur when this system is used in any way other than that for which it is intended.

To assure safe and proper operation, all supplied equipment, components and/or accessories must be carefully transported and stored, as well as professionally installed and operated. Careful maintenance and usage in full accordance with operating instructions is imperative.

CORRSYS-DATRON equipment should be installed and operated only by qualified persons who are familiar with devices of this type.

Local regulations may not permit the operation of motor vehicles on public highways while the equipment is mounted on the exterior of the vehicle.

- Use the equipment only for intended applications. Improper application is not advised.
- Do not modify or change the equipment or its accessories in any way.
- Improper use or mounting of the equipment may affect the safety of the vehicle and/or occupants.
- The equipment must not be mounted and/or operated in any way that may compromise vehicle or and/or occupant safety.
- Equipment must be mounted firmly and securely.
- Use only original equipment, components and/or accessories included in the scope of delivery.
- Do not mount equipment, components and/or accessories near heat sources (e.g. exhaust).
- Do not use defective or damaged equipment, components and/or accessories .
- Always note correct pin assignments and operating voltages when connecting equipment to power supplies, data acquisition/evaluation systems, and/or any other applicable system or component. Equipment may be damaged if not properly connected and/or operated.
- For additional information, please call the CORRSYS-DATRON Hotline: ++49 (6441) 92 82 82 or email: hotline@corrsys-datron.com.



Danger

- Use caution when exchanging sensor lamps – lamps are extremely hot, and may cause injury.
- Do not look into sensor lamps – lamps are extremely bright, and may cause eye injury.
- Sensor head can become very hot and may cause injury if power has been applied to the sensor for extended periods of time. This is especially true if the sensor is used in hot environmental conditions.



Warning

- The sensor and/or sensor components may be damaged if power is applied for extended periods, especially in hot environmental conditions.



- Disconnect power from the sensor if the vehicle is stationary for extended periods.

CORRSYS**DATRON**

Sensorsysteme GmbH

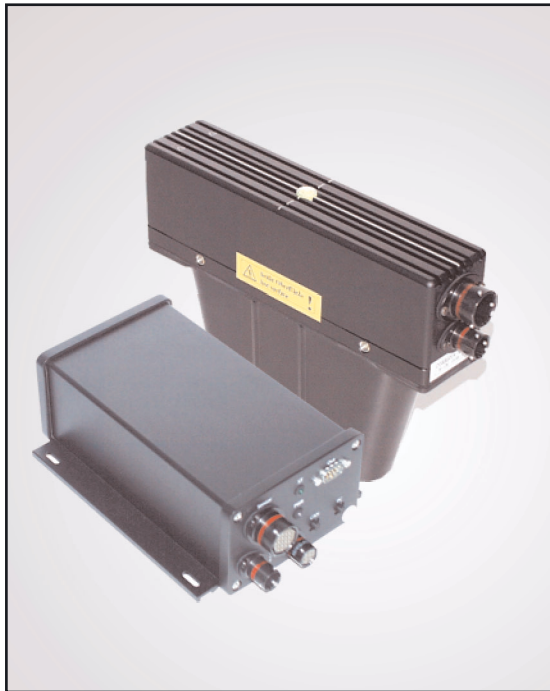

1. Overview

**CORREVIT®**
H-CE™**Non-Contact
Optical Sensor***for**slip-free measurement
of vehicle ride height*

H-CE longitudinal	11320
H-CE transversal	11321

The CORREVIT® H-CE Sensor measures the distance between the vehicle and the road or track surface. Measurement values are provided as analog signals, ensuring that the sensor system can be connected to virtually any data acquisition system. A CAN output for connection to data acquisition is also standard.

The sensor is configured with the included CeCaWin Software Package using a PC, connected via standard serial interface.

Features

- Extended operating range of 400 mm \pm 130 mm.
- Height measurement range from 1.5 kph to 350 kph.
- Programmable standardized analog and digital signal outputs using the latest processor techniques
- Fast, easy set-up and calibration with the included CeCalWin Software Package.
- Any required measurement quantity available.
- Easy operation, mounting angle correction and direct connection to PC or other evaluation systems.
- Negligible service and maintenance requirements.
- Tested and used under extreme environmental conditions.

Applications

The CORREVIT® H-CE is designed for use in dynamic vehicle testing applications that require highly accurate measurement of ride height

2. Extend of Delivery



Item	Qty.	Description
1.	(1)	H-CE Sensor
2.	(1)	H-CE Electronics Box
3.	(1)	Power Cable #K003-16N-12-2m
4.	(1)	Sensor to Electronics Power Cable #K003-16N-10-5m
5.	(1)	Sensor to Electronics Box Cable #K003-1J2-11-5m
6.	(1)	RS232 Serial Communication Cable #K003-15N-11-2m
7.	(1)	CAN Bus Interface Cable #K003-14N-11-2m
8.	(1)	Signal Output to 1 BNC Adapter Cable #K008-192-10-1m
9.	(2)	Halogen Lamp, 35 watt, 12V, 10°
10.	(6)	Bolts (for mounting hardware)
11.	(2)	Thumb Screws (for mounting hardware)
12.	(1)	CD-ROM with CeCalWin Software and User Manual
	(1)	Calibration Certificate ISO 9000++

Options/Accessories

- Suction Mounting Hardware
- Transport Case
- German Calibration Service Certificate (Livingston / DKD)
- Replacement Halogen Lamp 35 watt, 12V, 10°

About replacement halogen lamps

To assure optimal sensor function, use only original-equipment lamps from CORRSYS-DATRON. These lamps are specially designed and treated to withstand the demands of dynamic vehicle testing.

3. Technical Data

3.1 Specifications

Performance Specifications

Height measurement range:	1.5 ... 350 kph
Working distance and range:	400 ± 130 mm
Height measurement resolution:	0.15 mm
Height measurement accuracy*:	±0.5 mm (±0.1% of full scale of the maximum working range - 530 mm)

Electronic Connector Output

Analog output 2 - height h: -10 ... +10 V

CAN Bus:

CAN V2.0B

System Specifications

Power requirement:	11.5 ... 14.5 V; 80 W (12 V DC)
Temperature range	Operation: - 25 ... 50° C
	Storage: - 40 ... 85° C
	Relative Humidity: 5 ... 80% non condensing
System protection of the sensor:	IP 67
Dimensions of the sensor (l x w x h):	247 x 52 x 171 mm
Weight:	1350 g
Dimensions of the electronics (l x w x h):	212 x 144 x 76 mm
Weight:	1200 g
Shock:	50 g half-sine, 6 ms
Vibration:	10 g, 10 ... 150 Hz

A serial interface on each of the sensor electronics enables connection to PC for automatic sensor identification, set-up and function control.

* with calibration on the test surface at 50 kph

3.2 Pin Assignments

3.2.1 Pin Assignment: Electronic Output

Cable: 9-Pin D-SUB to 1 BNC (#K008-192-10-1m)

D-SUB	Signal	Measurement Value	BNC
Pin 1	n.c.		
Pin 2	Analog 2	height h	ANA2
Pin 3	n.c.		
Pin 4	Analog GND		
Pin 5	n.c.		
Pin 6	n.c.		
Pin 7	n.c.		
Pin 8	n.c.		
Pin 9	n.c.		

3.2.2 CAN Bus Output

Cable: 4-pin CAN to 9-pin D-SUB (#K003-14N-11-2m)

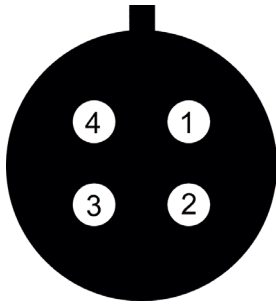

CAN connector

Pin 1: CAN High
 Pin 2: CAN Low
 Pin 3: n.c. (do not connect to this pin)
 Pin 4: n.c. (do not connect to this pin)

D-SUB connector

Pin 7 - CAN High
 Pin 2 - CAN Low

There is a 120 Ω termination resistor between Pins 1 and 2 of the CAN Connector

3.2.3 Pin Assignment: PC (RS 232) Output

Cable: 5-pin RS-232 to 9-pin D-SUB (#K003-15N-11-2m)

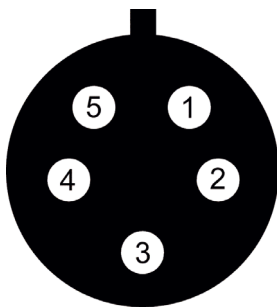

RS-232 connector

Pin 1: TXD
 Pin 2: RXD
 Pin 3: Digital GND
 Pin 4: n.c. (do not connect to this pin)
 Pin 5: n.c. (do not connect to this pin)

D-SUB connector

Pin 2 - TXD
 Pin 3 - RXD
 Pin 5 - Digital GND

3.2.4 Pin Assignment: Power Connectors

Cable: 6-pin to 2 banana plugs (#K003-16N-12-2m), electronic to power supply

Cable: 6-pin to 6-pin (#K003-16N-10-5m), electronic to sensor

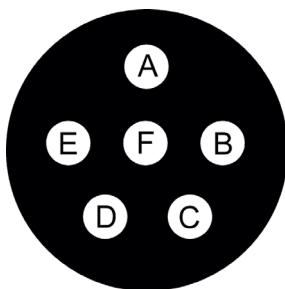

5-pin MIL connectors

Pins A, B, C: Power (+12 V)
 Pins D, E, F: GND (0 V)

Banana plugs

Red: Power (+12 V)
 Black: GND (0 V)

MIL Connector

06 10 98SN

3.3 Default Settings

H-CE Electronic Output

Analog channel 2	50	$\frac{mV}{mm}$	Height
------------------	----	-----------------	--------

Use CeCalWin to change the settings

3.4 Internal Signal Filtering

The height signal is internally filtered.
Filter time is speed dependent and cannot be adjusted

Speed Range [kph]	f_{3db} [Hz]
$v < 3$	1.5
$v < 20$	2
$v < 31$	5
$v < 37.5$	7.5
$v < 43$	10
$v < 50$	12.5
$v < 100$	15
$v > 100$	30

3.5 Typical Data Plot

Absolute Height Function

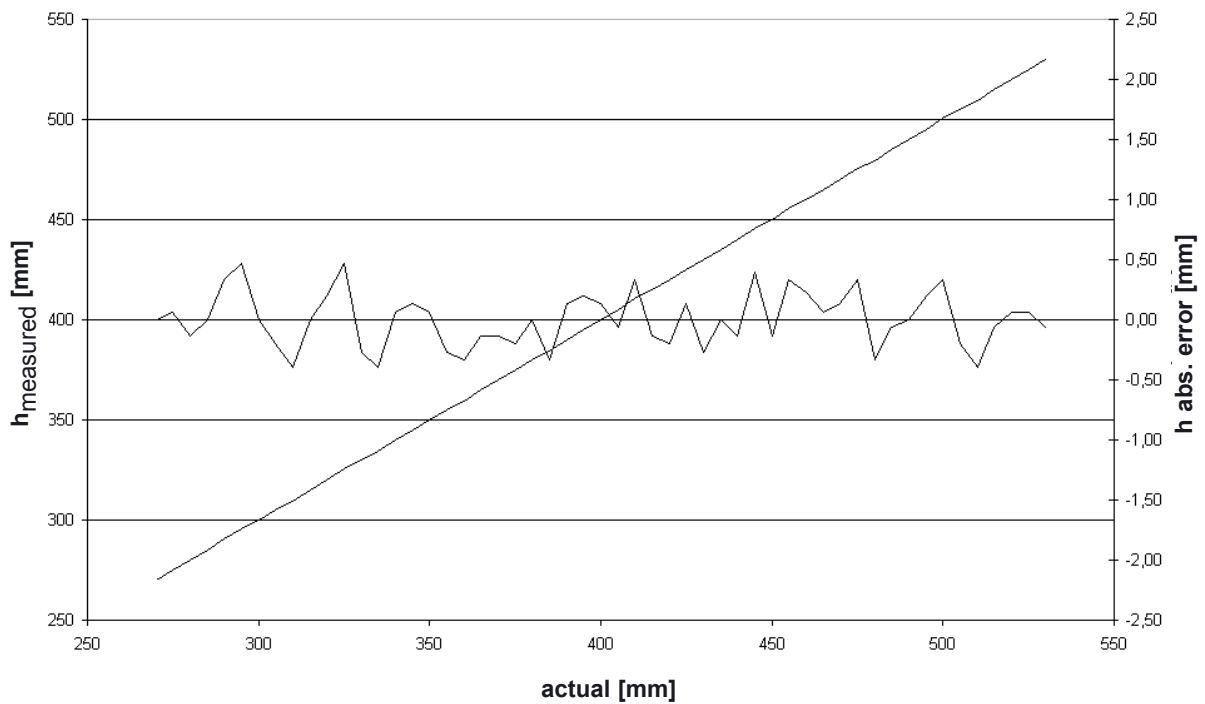

4. Set-up and Connection

4.1. Mounting options

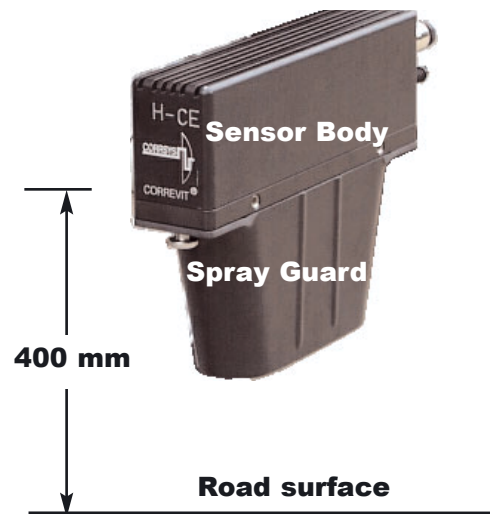
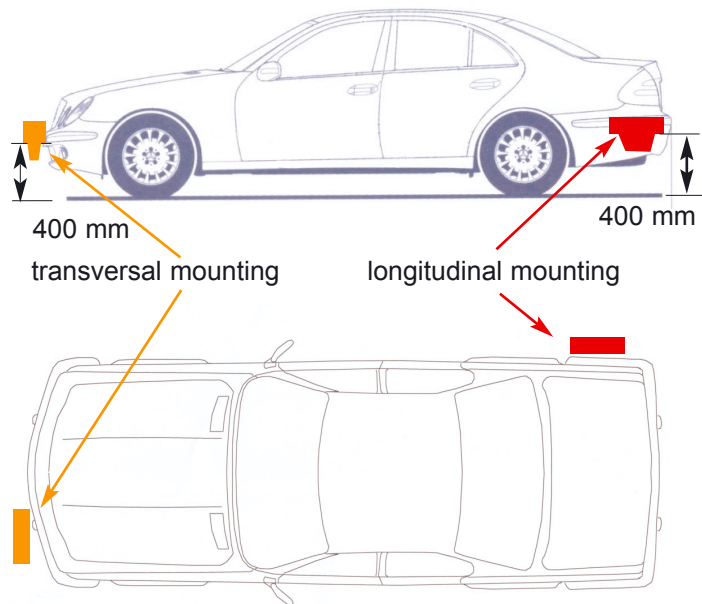

The mounting distance from the lower surface of the sensor body (not including the spray guard) to the road surface must be 400 mm.

4.2 Sensor orientation

The sensor must be mounted in the orientation indicated by the arrows imprinted on the top (sensors may be ordered with either longitudinal or transversal orientation). Care should be taken to assure that the plane of the sensor orientation is closely aligned to the direction of travel.

Arrows indicate direction of travel



Arrows indicate direction of travel

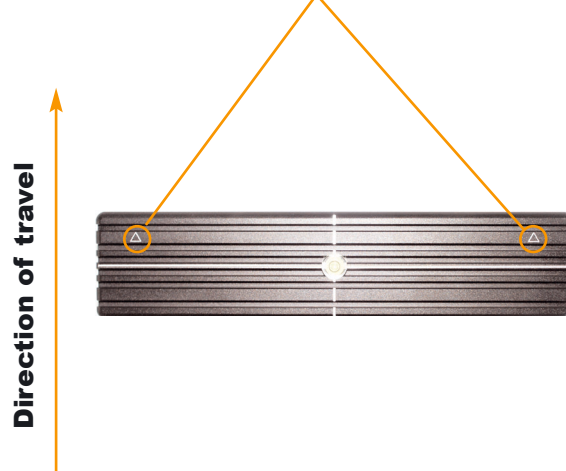

Notice:

In wet or snowy conditions, do not mount sensors directly behind the rear wheels. This will help to prevent measurement anomalies that can be caused by spray and/or blowing snow.

4.3 Sensor mounting jig

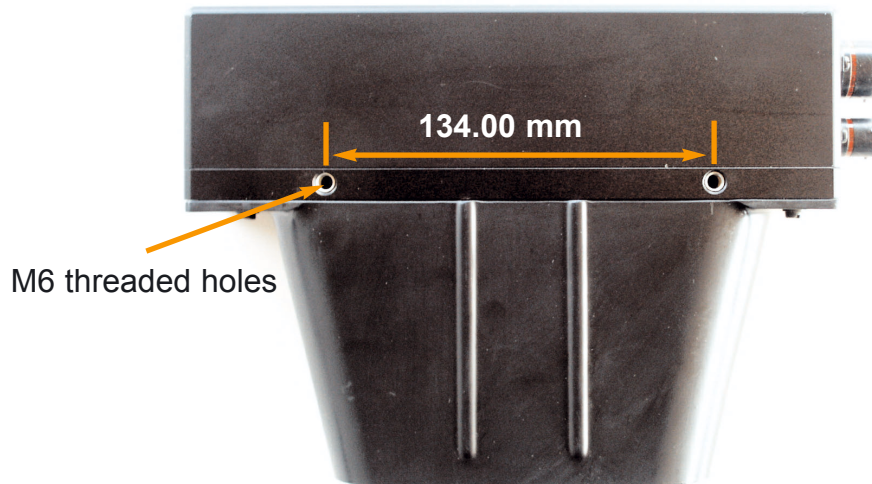

Caution:

For proper sensor mounting, use only M6 screws with a maximum thread engagement depth of 10 mm. The use of screws with thread engagement depths of greater than 10 mm can damage the sensor housing and will void the warranty!

4.4 Connecting the Sensor

Sensor Connections

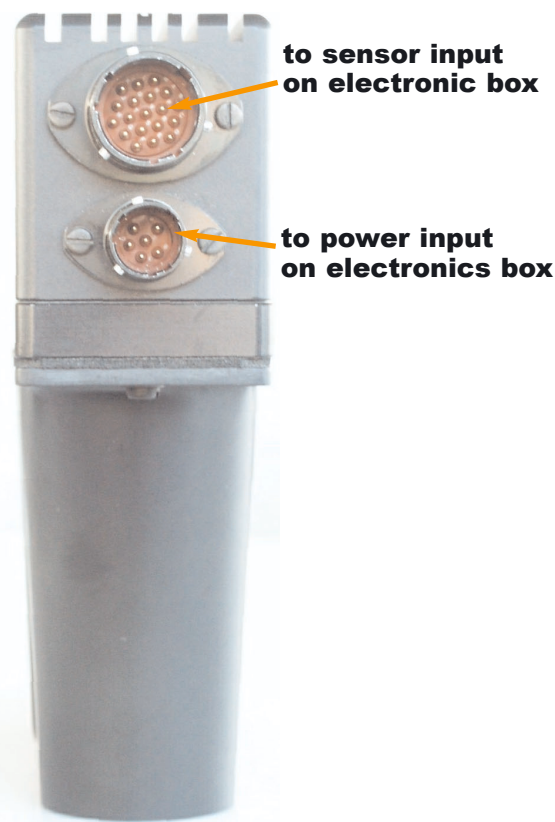

Sensor Electronic Connections

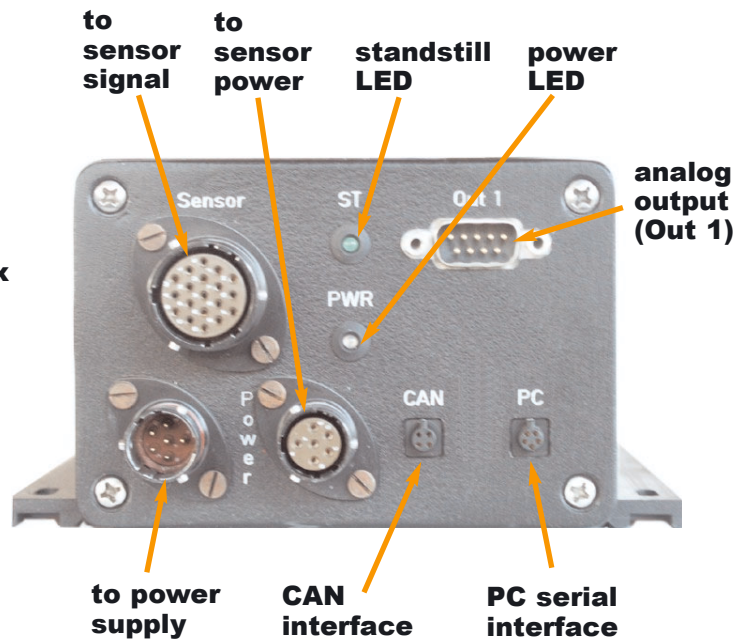

Reverse polarity protection

The electronic unit is equipped with reverse polarity protection. In the event that polarity is inverted, the unit will not be damaged but the power LED will illuminate red! Immediately disconnect power from the unit and correct the power supply connection.

1. Connect the sensor to the electronic unit:

NOTE: For easier connection, connect power cable to sensor before connecting signal cables.

- a) Connect the power input on the sensor to the power output on the electronic with 6-pin to 6-pin cable #K003-16N-10-5m.
- b) Connect signal output on the sensor to the signal input on the electronic with cable #K003-1J2-11-5m.

2. Connect the electronic to data acquisition.

- a) Connect H-CE electronic output (Out 1) with 9-Pin D-SUB to 1 BNC cable #K008-192-12-1m.
- b) Connect H-CE CAN connector to data acquisition with 4-pin CAN to 9-pin D-SUB cable #K003-14N-11-2m.

NOTE: The H-CE electronic is equipped with a termination resistor!

3. Connect the power cable from the electronic to a CORRSYS-DATRON power distribution unit with cable #K003-16N-12-2m (6-pin to 2 banana plugs).
4. Be sure that the individual switches on each power output circuit on the power distribution unit are in the "OFF" position.
5. Start the vehicle engine and carefully connect the power distribution unit to the vehicle power supply.
6. Switch the power circuit on to send power to the sensor electronics boxes.
7. The sensor is now ready for set-up and calibration using CeCalWin Software. Connect the RS (RS 232) PC output on the electronic to a PC operating CeCalWin (see **Using the CeCalWin Software Package** for complete details). Use the 5-pin RS-232 to 9-pin D-SUB serial communication cable (#K003-15N-11-2m) to make the connection between electronic and PC.

5. Troubleshooting

When troubleshooting the H-CE Sensor, begin by checking the following:

Cables and power supply

- Check all connections to determine that each is complete and that the system is connected to a power supply that provides voltage output within the specified range.
- Check to determine that the correct cables have been used for all connections.
- The following problems can be caused by incorrect or incomplete cable connections and/or connection to incorrect power supply voltage:
 - Output signals are not available to data acquisition and/or connected PC.
 - The sensor will not go out of standstill mode with vehicle motion..

Status LED's on sensor electronic

- If all connections are correct and no faults are present, the "PWR" (power) LED on the sensor electronic will be illuminated orange. If the "PWR" LED is red, a fault is indicated. Additionally, the green "ST" (standstill) LED will be illuminated if all connections are correct and no faults are present.
- If the "PWR" LED is red and the green "ST" LED is not illuminated, polarity has been reversed and must be corrected.
- If the "PWR" LED is orange and the green "ST" LED is not illuminated, cables may have been connected incorrectly. Check and reconnect cables as necessary.

Lamps

Check to be sure that both lamps in the sensor are illuminated. Check and replace lamps as necessary. Also be sure that connections and supply voltage are correct.

Sensor orientation

- The sensor is delivered with a user-specified operating orientation, which is indicated by arrows located on the top surface of the sensor housing. Sensors must be mounted with the arrows pointing in the direction of travel.
- Incorrect sensor orientation will cause all output signals to be incorrect.
- The height signal will not be correct when the vehicle is moving in reverse.

Operating range

If the sensor is mounted out of the recommended height range (standoff distance), it may not go out of standstill mode with vehicle motion, and no measurement signals will be output. Check and correct mounting as necessary.

Sensor lens

The sensor lens (located on the underside of the sensor housing) may occasionally become dirty, preventing proper operation. Check and clean the sensor lens regularly.

Software

- If one or more output signals appear to be incorrect, the sensor may have been set-up incorrectly via CeCalWin Software. Check all relevant settings in CeCalWin:
 - All analog voltage settings must be within range and should conform with the data acquisition system settings to which they are connected.
 - Check all offset values and recalibrate sensor(s) as necessary.
- If no output signals are available and all connections are correct, use the CeCalWin Test Function to determine that all outputs are fully operational. See Section 6, **Using the CeCalWin Software Package** for complete details.
- CeDapWin, an additional software package available from CORRSYS-DATRON, enables real-time monitoring of height, speed and other relevant signals with a laptop. CeDapWin can be useful for diagnostic purposes when used in conjunction with CeCalWin. Contact your CORRSYS-DATRON sales office for details about obtaining CeDapWin.

Environmental conditions

The sensor may occasionally interpret heavy spray from snow or water as part of the road or track surface, producing unexplained spikes in the output signals and/or other anomalous measurement artifacts. Sensors should be mounted away from the heaviest spray areas, especially directly behind the rear wheels.

EMC interference

If the sensor starts to send output signals without vehicle motion, triggering may have been caused by excessive EMC interference from the test vehicle. To correct this condition, reset the sensor by disconnecting from power and then re-connecting, or by switching power off and then back on. If the condition persists, disconnect sensor from vehicle ground and isolate it at all mounting points

If none of the above recommendations provides a solution, you may wish to contact CORRSYS-DATRON. Before doing so, please be ready to supply the following:

- A .ccw file saved from CeCalWin software to serve as an example of the problem or fault condition.
- A list of all outputs that appear to be problematic, i.e. analog, digital, CAN, RS-232.
- The serial numbers of all relevant components.

Troubleshooting CAN

Problem: There are no messages on the CAN-bus

Check to be sure that:

- the electronic has power
- data acquisition is connected to the sensor electronic
- the correct send mode is selected
- data acquisition system and sensor electronics use the same settings for baud rate, CAN identifiers and identifier types
- if you use CANalyser or a data acquisition system with an acceptance filter, be sure the message from the Sensor is not disabled

Problem: Data received via the CAN bus appear to be incorrect

Please be sure that:

- the data acquisition system uses Intel data format for communication via CAN-bus
- the data acquisition system and sensor electronic use the same settings for the type of measured value (signed or unsigned, number of bits)

For more information about data types and how they apply to this Sensor, see the **CAN Protocol** document located in the Appendix of this manual.

CORRSYS-DATRON recommends that the .dbc file option be used to avoid problems with false data types or bit lengths. Sensor-specific .dbc files are available for download at www.corrsys-datron.com, or may also be obtained by contacting the CORRSYS-DATRON application department directly.

Problem: No height information is available on the CAN-bus.

Please be sure that:

- the electronic has power
- the electronic is connected to the sensor
- the data acquisition system uses the same settings as the sensor

Appendix

