CORRSYS

DATRON

Sensorsysteme GmbH



CORREVIT[®] SLR[™]

Non-Contact Optical Sensor System

for

slip-free measurement of

longitudinal and transversal dynamics

USER MANUAL

Notes:

Table of Contents

General Information	4
Safety Instructions	5
1. Overview	6
2. Extent of Delivery	8
3. Technical Data	9
3.1 Specifications	9
3.2 Pin Assignments	10
3.2.1 Sensor Output	10
3.2.2 Output Connector	10
3.2.3 Power Output	10
3.2.2 RS232 / CAN Output	10
3.3 Default Settings for Analog and Digital Outputs	11
3.3.1 Analog Output Default Settings	11
3.3.2 Digital Output Default Settings	11
3.4 Internal Signal Filtering	12
3.4.1 Filter Values for Speed and Slip Angle Output	12
3.5 Typical Data Plots	12
4. Set-up and Connection	13
4.1 Mounting Options	13
4.2 Sensor Mounting Jig	13
4.3 Wheel Mount Set-Up	14
4.4 Connecting the Sensor	21
5. Troubleshooting	22

Appendix: Technical Drawings

CORREVIT® is a registered trademark of CORRSYS-DATRON Sensorsysteme GmbH, Wetzlar Germany. In a continuous effort to improve our products CORRSYS-DATRON reserves the right to change specifications without prior notice.

General Information

Legal Notice

Information furnished is believed to be accurate and reliable. However, CORRSYS-DATRON assumes no responsibility for the consequences of use of such information nor for any infringement of patents or other rights of third parties which may result from its use. No license is granted by implication or otherwise under any patent or patent rights of CORRSYS-DATRON. Specifications mentioned in this publication are subject to change without notice and do not represent a commitment on the part of CORRSYS-DATRON. This publication supersedes and replaces all information previously supplied.

All brand names are trademarks of their respective holders.

Copyright Notice

© Copyright 2004, CORRSYS-DATRON

Revision

D035-50-01-02E 11/04 - preliminary

Contact

International Headquarters:

CORRSYS-DATRON Sensorsysteme GmbH

Charlotte-Bamberg-Str. 12

35523 Wetzlar / Germany

Phone ++49 (6441) 9282-0

Hotline ++49 (6441) 9282-82

Fax ++49 (6441) 9282-17

E-mail sales@corrsys-datron.com

URL www.corrsys-datron.com

North American Headquarters:

CORRSYS-DATRON Sensorsystems, Inc.

21654 Melrose Avenue, Building 16

Southfield, MI 48075 / USA

Phone ++1 (248) 204-0850

Toll-free++1 (800) 832-0732

Fax ++1 (248) 204-0864

E-mail sales@datron.com or USA-sales@corrsys-datron.com

URL www.corrsys-datron.com

Safety Instructions

Please read carefully before operating the equipment.

CORRSYS-DATRON is not responsible for damage that may occur when this system is used in any way other than that for which it is intended.

To assure safe and proper operation, all supplied equipment, components and/or accessories must be carefully transported and stored, as well as professionally installed and operated. Careful maintenance and usage in full accordance with operating instructions is imperative.

CORRSYS-DATRON equipment should be installed and operated only by qualified persons who are familiar with devices of this type.

Local regulations may not permit the operation of motor vehicles on public highways while the equipment is mounted on the exterior of the vehicle.

- Use the equipment only for intended applications. Improper application is not advised.
- Do not modify or change the equipment or its accessories in any way.
- Improper use or mounting of the equipment may affect the safety of the vehicle and/or occupants.
- The equipment must not be mounted and/or operated in any way that may compromise vehicle or and/or occupant safety.
- Equipment must be mounted firmly and securely.
- Use only original equipment, components and/or accessories included in the scope of delivery.
- Do not mount equipment, components and/or accessories near heat sources (e.g. exhaust).
- Do not use defective or damaged equipment, components and/or accessories .
- Always note correct pin assignments and operating voltages when connecting equipment to power supplies, data acquisition/evaluation systems, and/or any other applicable system or component. Equipment may be damaged if not properly connected and/or operated.
- For additional information, please call the CORRSYS-DATRON Hotline: ++49 (6441) 9282-82



Danger

- Use caution when exchanging sensor lamps – lamps are extremely hot, and may cause injury.
- Do not look into sensor lamps – lamps are extremely bright, and may cause eye injury.
- Sensor head can become very hot and may cause injury if power has been applied to the sensor for extended periods of time. This is especially true if the sensor is used in hot environmental conditions.



Warning

- The sensor and/or sensor components may be damaged if power is applied for extended periods, especially in hot environmental conditions.



- Disconnect power from the sensor if the vehicle is stationary for extended periods.

CORRSYS
DATRON
Sensorsysteme GmbH



1. Overview



CORREVIT® SLR™

Non-Contact Optical Sensor

*for
slip-free measurement of
longitudinal and transversal
dynamics*

Art. No.
SLR 11315

Optimizing the dynamics of vehicle movement is a primary focus of development within the automotive industry. In this process, the accurate measurement of longitudinal distance and speed, as well as transversal speed, plays an important role.

The CORREVIT® SLR Sensor is especially developed for the measurement of tire slip angle. The low weight and compact design of the sensor have negligible affect on tire slip angle, providing more accurate results.

The CORREVIT® SLR Sensor uses proven optical correlation technology to ensure the most accurate possible signal presentation. This technology incorporates a high-intensity light source that illuminates the test surface, which is imaged by the sensor onto an optical grating system. Fast, easy mounting and universal applicability distinguish this proven non-contact, optical sensor.

Features

- Developed for measurement of tire slip angle at speeds up to 400 km/h.
- Smaller and lighter version of the proven CORREVIT® SL Sensor.
- Same performance characteristics as the CORREVIT® SL Sensor.
- Extremely high measuring accuracy – better than $\pm 0.1\%$ * (better than $\pm 0.1^\circ$ angle resolution).
- Easy operation, mounting angle correction and direct connection to PC or other evaluation system.
- Negligible service and maintenance requirements as a result of durable technology.
- Tested and used under extreme environmental conditions.
- MIL connectors for automobile sport
- CFK spray guard

Applications

The compact, ultra lightweight CORRSYS-DATRON SLR Sensor is designed for use in dynamic vehicle testing applications that require highly accurate measurement of the following variables:

- Distance
- Speed
- Longitudinal and transversal speed
- Tire slip angle
- Drift angle

* with calibration on the test surface

2. Extent of Delivery

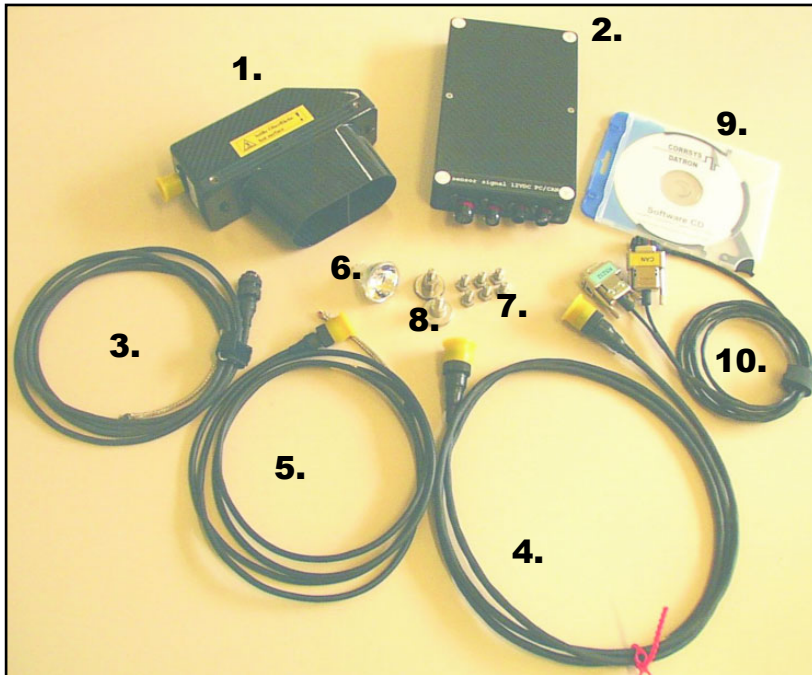

Standard delivery

1. (1) SLR sensor
2. (1) SLR electronics box
3. (1) Power cable 2m open end (#10415)
4. (1) Sensor to electronics box cable 2m (#10429)
5. (1) Signal cable 2m open end (#10472)
6. (1) Halogen lamp, 35 watt, 12V, 24°
7. (6) Bolts (for mounting hardware)
8. (2) Thumb screws (for mounting hardware)
9. (1) CD-ROM with CeCalWin software and user manual
10. (1) Signal cable RS232 / CAN #K042-260-10-2m (#13449)
(1) Calibration certificate ISO 9000++

Options/Accessories

- Suction mounting hardware
- Wheel mounting unit
- Transport Case, various - on request
- German calibration service certificate (Livingston)
- Replacement halogen lamp 35 watt, 12V, 24°
- Longer cables, special cables on request
- Spare splash guard

About replacement halogen lamps

It is recommended that only halogen lamps supplied by CORRSYS-DATRON be used as these have been subjected to a special treatment. Optimal sensor function can only be assured when using original-equipment lamps.

3. Technical Data

3.1 Specifications

Performance Specifications

Speed range:	0.5 ... 400 km/h
Distance resolution:	2.5 mm
Measurement deviation*:	<±0.1%
Angle range:	±40°
Angle resolution:	<±0.1°
Working distance and range	300 ±50 mm

Electronic Connector Output

Digital output 1 - distance IVI or V_L :	1 ... 1000 pulses/m
Digital output 2 - switchable:	Output as frequency
- Frequency modulated angle or transversal speed:	$F_C = 5$ kHz
Analog output 1 - IVI or V_L :	0 ... 10 V
Analog output 2 - switchable transverse speed or angle:	-10 ... +10 V

CAN Bus (optional):

CAN V2.0B

System Specifications

Power supply:	11.5 ... 14.5 V; 45 W (at 12 V DC)
Temperature range	Operation: - 25 ... 50° C
	Storage: - 40 ... 85° C
	Relative Humidity: 5 to 80% not condensing
System protection of the sensor:	IP 67
Dimensions of the sensor (l x w x h):	180 x 52 x 120 mm
Weight:	500 g
Dimensions of the electronics (l x w x h):	206 x 116 x 35 mm
Weight:	800 g
Shock:	50 g half-sine, 6 ms
Vibration:	10 g, 10 ... 150Hz

Serial interface for connection to the PC automatic sensor identification, function control.

* with calibration on the test surface

3.2 Pin Assignments

3.2.1 Pin Assignment: Sensor Output

Cable: Sensor to electronics box

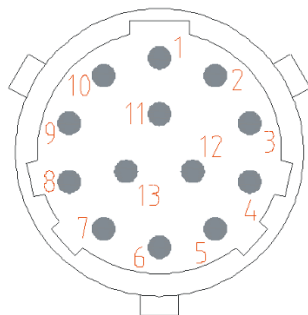

female

Sensor Connector

Pin 1 - 7:	Minimum diameter AWG 24
Pin 8:	Cable shield
Pin 9 - 12:	Minimum diameter AWG 22

3.2.2 Pin Assignment: Output Connector

Cable: Signal cable

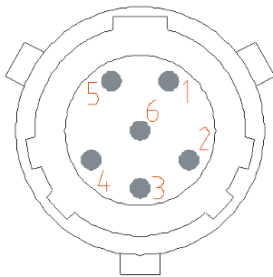

female

RS-232 connector

Pin 1:	Analog V or VL	red
Pin 2:	Analog β	blue
Pin 3:	Digital V or VL	violet
Pin 4:	Digital β	green
Pin 5:	Analog GND	yellow
Pin 6:	Digital GND	orange

3.2.3 Pin Assignment: Power Output

Cable: Power cable

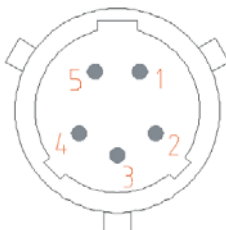

male

Power Connector

Pin 1 & 2:	+12V	red, orange
Pin 3 & 4:	GND	brown, blue
Pin 5:		

3.2.4 Pin Assignment: RS232 / CAN Output

Cable: RS232/CAN cable

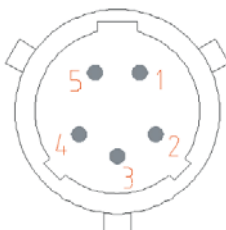

female

Power Connector

Pin 1:	+12V	red
Pin 2:	CAN-L	orange
Pin 3:	Shield	
Pin 4:	CAN-H	blue
Pin 5:	0 V	black

3.3 Default Settings for Analog and Digital Outputs

3.3.1 Analog Output Default Settings

Analog channel 1	25	$\frac{\text{mV}}{\text{km/h}}$	Magnitude speed $ V $
Analog channel 2	100	$\frac{\text{mV}}{\text{km/h}}$	Transverse speed Vq
Analog channel 3	100	$\frac{\text{mV}}{^\circ}$	Angle β

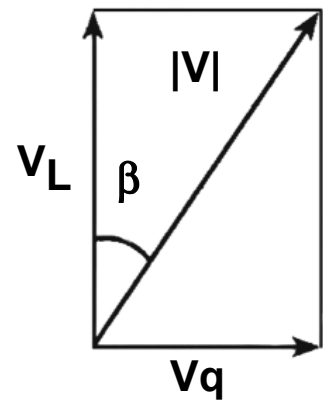

The above settings produce the following values:

100 km/h	=	2.5 V
200 km/h	=	5.0 V
300 km/h	=	7.5 V
400 km/h	=	10.0 V

With a setting of 25 mV/km/h for magnitude speed $|V|$, a maximum speed of 400 km/h can be achieved.

All signals can be used as inputs to all common data acquisition systems.
Should any problems arise, please contact CORRSYS-DATRON.

For analog signal representation of speed, the voltage scale may be changed to between 10 and 500 mV/km/h.

Use CeCalWin Software to change the settings.

3.3.2 Digital Output Default Settings

The calibrated CORREVIT® SL Sensor generate 50% duty cycle pulses on both digital outputs. Digital 1 provides a specified number of digital pulses per meter. Digital 2 supplies a frequency modulated signal for either transversal speed (default 5 kHz \pm 100Hz/km/h) or slip angle (default 5 kHz \pm 50 Hz/deg).

Digital channel 1	340	$\frac{\text{pulses}}{\text{m}}$	Longitudinal distance (output as pulses)
Digital channel 2	50	$\frac{\text{Hz}}{^\circ}$	Angle (output as frequency)

Use CeCalWin Software to change the settings.

3.4 Internal Signal Filtering

Signals may be smoothed using a moving average filter, which can be set to different time values. Note that signal detail and dynamics will decrease as the signal becomes increasingly smooth.

3.4.1 Filter Values for Speed and Slip Angle Output

- 8 ms
 - 16 ms
 - 32 ms
 - 64 ms
 - 128 ms (default setting)
 - 256 ms
 - 508 ms
- 
- increased signal detail and dynamics (as well as noise)
 minimum signal delay
- smoothest signal
 maximum signal delay

Use CeCalWin Software to change filter settings.

3.6 Typical Data Plots

slip angle

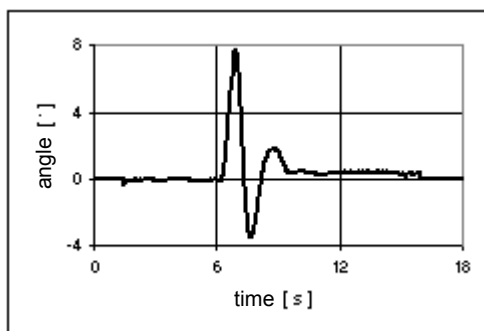

speed |v|

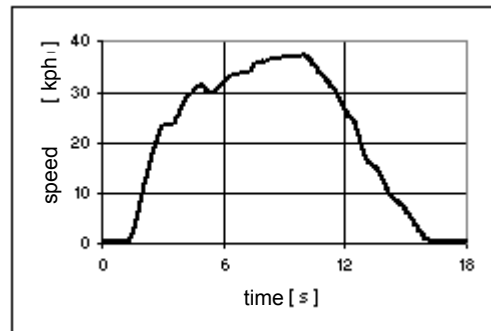

4. Set-up and Connection

4.1 Mounting Options

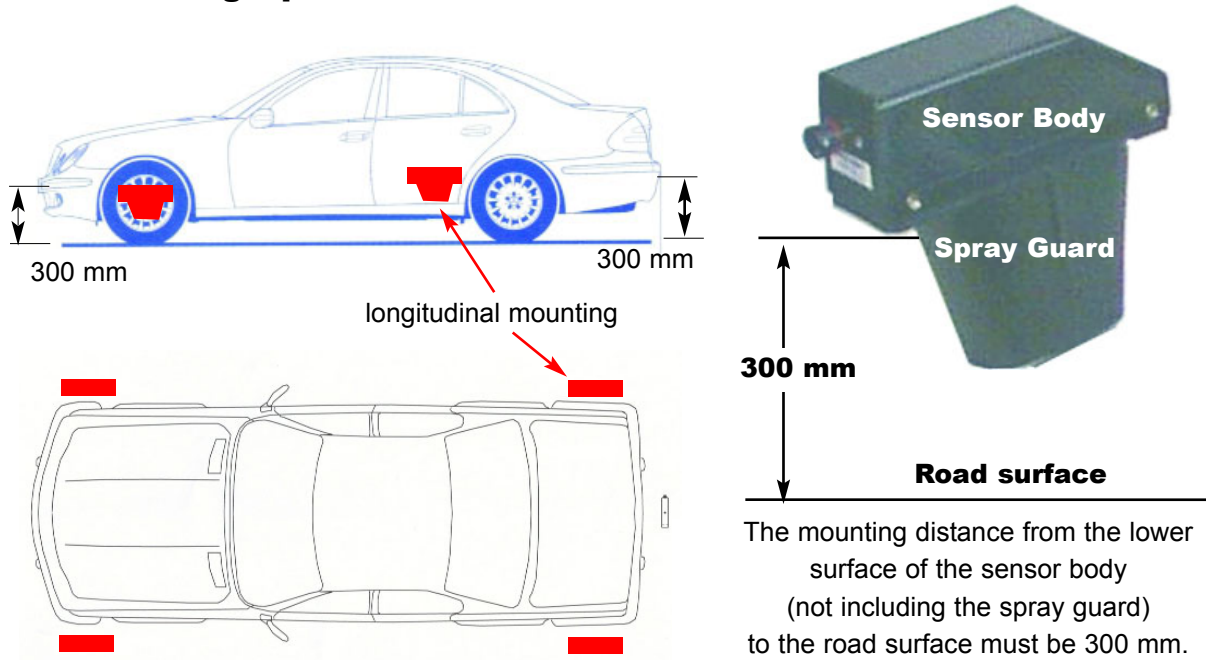

Notice:

In wet or snowy conditions, do not mount sensors directly behind the rear wheels. This will help to prevent measurement anomalies that can be caused by spray and/or blowing snow.

4.2 Sensor Mounting Jig

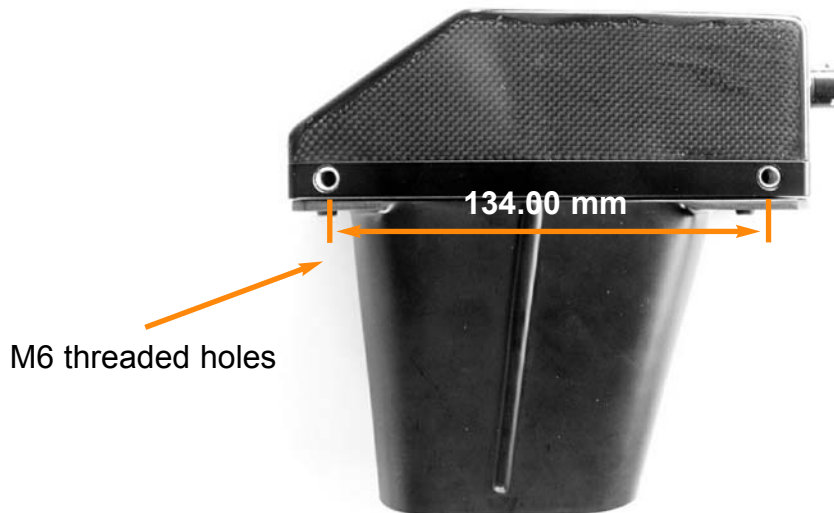

Caution:

For proper sensor mounting, use only M6 screws with a maximum thread engagement depth of 10 mm. The use of screws with thread engagement depths of greater than 10 mm can damage the sensor housing and will void the warranty!

4.3 Wheel Mount Set-Up

The CORRSYS-DATRON Wheel Mount System is designed to enable precision tire-slip measurement with CORREVIT® SL and SLR Optical Sensors.

We recommend use of the following mouning units



1. (1) Torsion rod, upper section, with protective boo (*)
2. (1) Suction mounting unit (*)
3. (1) Torsion rod, lower section, with protective boot (*)
4. (1) Torsion rod mounting clamp (*)
5. (1) Mounting disk with mounting hub (*)
6. (6) Centering stars (1 each for 3-, 4- and 5-lug hubs - #11295, 11293, 11294)
7. (14) Mounting collets for various lug nut sizes (**)

(*) part of the sensor mouning unit wheel, #11424

(**) standard dimensions: 17 mm, #10070
 19 mm, #10071
 21 mm, #10072

further on request

1. Remove hubcap or any covering over wheel nuts and clean dirt/debris from wheel nuts.



2. Place collets on wheel nuts.



3. Position the mounting disc and attach it loosely to collets with mounting bolts and washers. **NOTE:** The mounting disc has 3 sets of slots for proper alignment with 3-, 4-, and 5-lug configurations. Each set of slots is marked 3x, 4x or 5x, corresponding the number of lugs.



- Place the centering star tightly against the mounting disk and position the concave edges of the centering star against the washers on the mounting bolts, as shown. Then, turn the centering star until it is tight against all of the washers to ensure that the mounting disk is properly centered on the wheel.



- Continue to hold the centering star tightly against the mounting washers and mounting disk, then tighten the mounting bolts in a cross pattern, using a (need size) allen wrench.



- Using a (need size) allen wrench, loosen the set-screw at the bottom of the torsion rod retainer clamp and place the retainer clamp onto the mounting hub. **NOTE:** The set screw should not be tightened until after the torsion rod is properly positioned, see Step 11.

torsion rod
mounting hub
retainer clamp set screw



7. Slip the protective boots over the lower and upper sections of the torsion rod. Then, fit the upper section of the torsion rod into the joiner section at the top of the lower section of the torsion rod. Be sure to check the safety line to be sure it is secured to the torsion rod.



8. Clean the painted surface of the vehicle fender (do not use any cleaning product that leaves residue of any kind on the surface), then place the suction holders firmly against the vehicle fender and latch the suction holder lock handles (latched position is approximately parallel to vehicle fender surface).



9. Tighten the set screws that secure the upper and lower sections of the torsion rods together, using a (need size) allen wrench.



10. Tighten the nut that secures the suction holder mounting to the torsion rod.



11. Tighten the retainer clamp set-screw with a (need size) allen wrench.

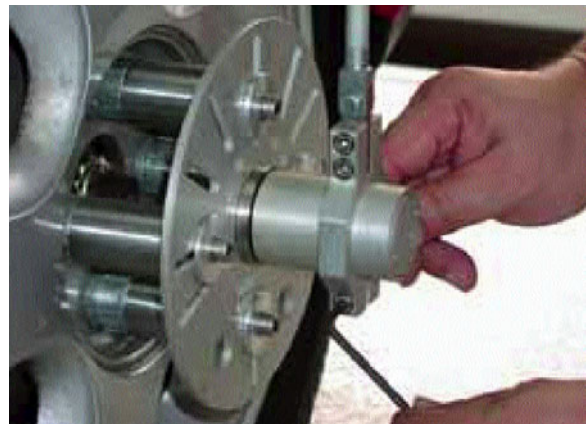

12. Secure the safety line around the windshield wiper drive shaft on the side opposite the Wheel Mounting System

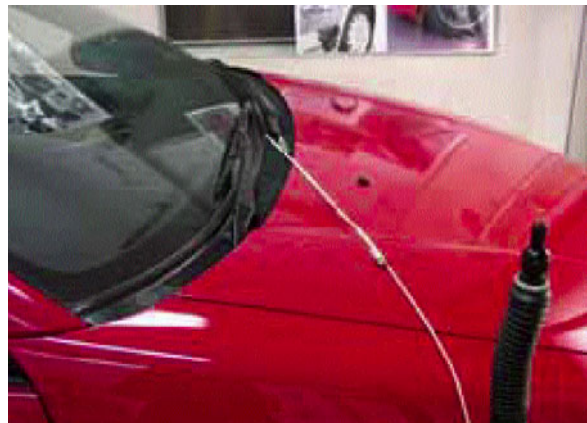

13. Loosen the sensor mounting retainer set-screw with a (need size) allen wrench.

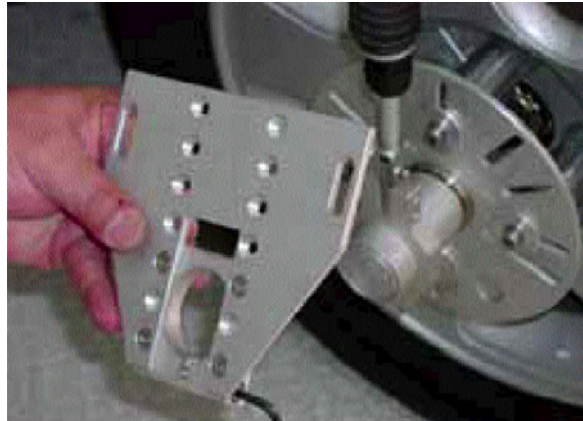

14. Place the mounting plate onto the mounting hub and tighten the set-screw.



15. Secure the sensor to the mounting plate with the two (2) thumb screws.



16. Measure the sensor mounting height to be sure that the sensor is within the specified vertical operating range. This distance is measured from the bottom of the sensor body to the road or track surface.

**bottom
of sensor
body**



17. If the sensor is not within the specified vertical operating range, first loosen the thumb screws and move the sensor up or down, as required, in the channels on the mounting plate and measure again. If this adjustment is insufficient, remove the mounting plate from the retainer clamp, as shown, using a (need size) allen wrench. Move the plate up or down as required and re-attach the plate to the mounting plate, then securely re-mount the sensor to the mounting plate.



18. Connect the signal cable to the sensor, then wind the cable loosely around the torsion bar, as shown.



Danger

WARNING:

Be sure to leave enough slack in the cable to allow for full-lock steering changes, but use caution to assure that the cable is not wound too loosely around the torsion bar. Under no circumstances should the cable be loose enough to touch the tire or to be pulled under the fender during testing. Either circumstance would inevitably result in damage to the equipment and could also cause an accident.

Finally, connect the cable to data acquisition.



4.4 Connecting the Sensor

Sensor Connections



to
Electronics
Box

Sensor Electronic Connections

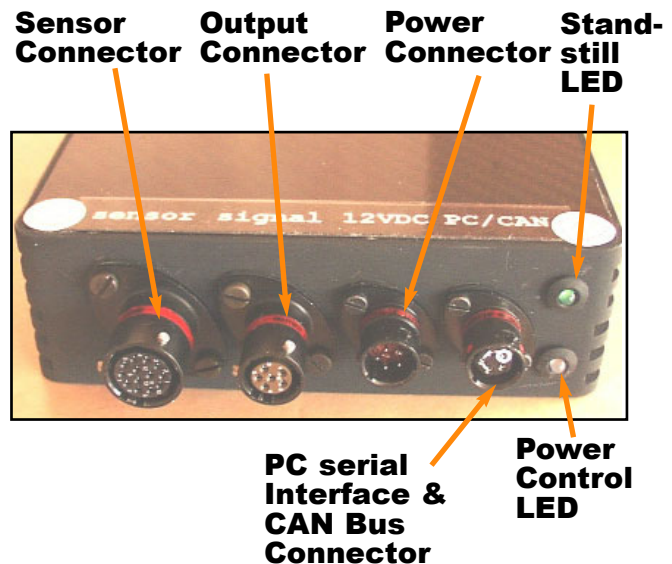

Reverse polarity protection

The electronic unit is equipped with reverse polarity protection. In the event that polarity is inverted, the unit will not be damaged but the power LED will illuminate red! Immediately disconnect power from the unit and correct the power supply connection.

1. Connect the sensor to the electronic unit:
Connect sensor output on the sensor to the sensor input on the electronic with: Sensor to electronics cable
2. Connect the electronic to data acquisition.
 - a) Connect the data acquisition with: signal cable.
 - b) (Optional) Connect the CAN connector to data acquisition with: RS232/CAN cable.

NOTE: The SLR electronic is equipped with a 120 Ω termination resistor!

3. Connect the power cable from the electronic to a CORRSYS-DATRON power distribution unit with: power cable.
4. Be sure that the individual switches on each power output circuit on the power distribution unit are in the "OFF" position.
5. Start the vehicle engine and carefully connect the power distribution unit to the vehicle power supply.
6. Switch the power circuit on to send power to the sensor electronics boxes.
7. The sensor is now ready for set-up and calibration using CeCalWin Software. Connect the RS (RS 232) PC output on the electronic to a PC operating CeCalWin (see **Using the CeCalWin Software Package** for complete details). Use the 5-pin RS-232/CAN cable to make the connection between electronic and PC.

5. Troubleshooting

When troubleshooting the CORREVIT® SLR Sensor, begin by checking the following:

Cables and power supply

- Check all connections to determine that each is complete and that the system is connected to a power supply that provides voltage output within the specified range.
- Check to determine that the correct cables have been used for all connections.
- The following problems can be caused by incorrect or incomplete cable connections and/or connection to incorrect power supply voltage:
 - Output signals are not available to data acquisition and/or connected PC.
 - A sensor will not go out of standstill mode with vehicle motion.

Status LED's on sensor electronic boxes

- If all connections are correct and no faults are present, the "PWR" (power) LED on the sensor electronic will be illuminated orange. If the "PWR" LED is red, a fault is indicated. Additionally, the green "ST" (standstill) LED will be illuminated if all connections are correct and no faults are present.
- If the "PWR" LED is red and the green "ST" LED is not illuminated, polarity has been reversed and must be corrected.
- If the "PWR" LED is orange and the green "ST" LED is not illuminated, cables may have been connected incorrectly. Check and reconnect cables as necessary.

Lamps

Check to be sure that all lamps in the sensor are illuminated. Check and replace lamps as necessary. Also be sure that connections and supply voltage are correct.

Operating range

If one or more sensor(s) is mounted out of the recommended height range (standoff distance), it may not go out of standstill mode with vehicle motion, and no measurement signals will be output. Check and correct mounting as necessary.

Sensor lens

The sensor lens (located on the underside of the sensor housing) may occasionally become dirty, preventing proper operation. Check and clean the sensor lens regularly.

Software

- If one or more output signals appear to be incorrect, the sensor may have been set-up incorrectly via CeCalWin Software. Check all relevant settings in CeCalWin:
 - All analog voltage settings must be within range and (within each channel) should be the same for every sensor, as well as for the data acquisition system to which they are connected.
 - All digital pulse and resolution settings must be set within range and (within each channel) should be the same for every sensor, as well as for the data acquisition system to which they are connected.
 - Check all offset values and recalibrate sensor as necessary.
- If no output signals are available and all connections are correct, use the CeCalWin Test Function to determine that all outputs are fully operational. See the CeCalWin Software User Manual for complete details.
- CeDapWin, an additional software package available from CORRSYS-DATRON, enables real-time monitoring of height, speed and other relevant signals with a laptop. CeDapWin can be useful for diagnostic purposes when used in conjunction with CeCalWin. Contact your CORRSYS-DATRON sales office for details about obtaining CeDapWin.

Environmental conditions

The sensor may occasionally interpret heavy spray from snow or water as part of the road or track surface, producing unexplained spikes in the output signals and/or other anomalous measurement artifacts. Sensors should be mounted away from the heaviest spray areas, especially directly behind the rear wheels.

EMC interference

If the sensor starts to send output signals without vehicle motion, triggering may have been caused by excessive EMC interference from the test vehicle. To correct this condition, reset the sensor by disconnecting from power and then re-connecting, or by switching power off and then back on at the power distribution box. If the condition persists, disconnect sensor from vehicle ground and isolate it at all mounting points

If none of the above recommendations provides a solution, you may wish to contact CORRSYS-DATRON. Before doing so, please be ready to supply the following:

- A .ccw file saved from CeCalWin software to serve as an example of the problem or fault condition.
- A list of all which outputs that appear to be problematic, i.e. analog, digital, CAN, RS-232.
- The serial numbers of all relevant components.

Troubleshooting CAN with the CORREVIT® SLR Sensor

Problem: There are no messages on the CAN-bus

Check to be sure that:

- the electronic unit has power
- data acquisition is connected to the SLR sensor electronic
- the correct send mode is selected
- the data acquisition system and all sensor electronics use the same settings for baud rate, CAN identifiers and identifier types
- if you use CANalyser or a data acquisition system with an acceptance filter, be sure the message from the sensor is not disabled

Problem: Data received via the CAN bus appear to be incorrect

Please be sure that:

- the data acquisition system uses Intel data format for communication via CAN-bus
- the data acquisition system and all sensor electronics use the same settings for the type of measured value (signed or unsigned, number of bits)

For more information about data types and how they apply to this sensor, see the **CAN Protocol** document located in the Appendix of this manual.

CORRSYS-DATRON recommends that the .dbc file option be used to avoid problems with false data types or bit lengths. Sensor-specific .dbc files are available for download at www.corrsys-datron.com, or may also be obtained by contacting the CORRSYS-DATRON application department directly.

APPENDIX

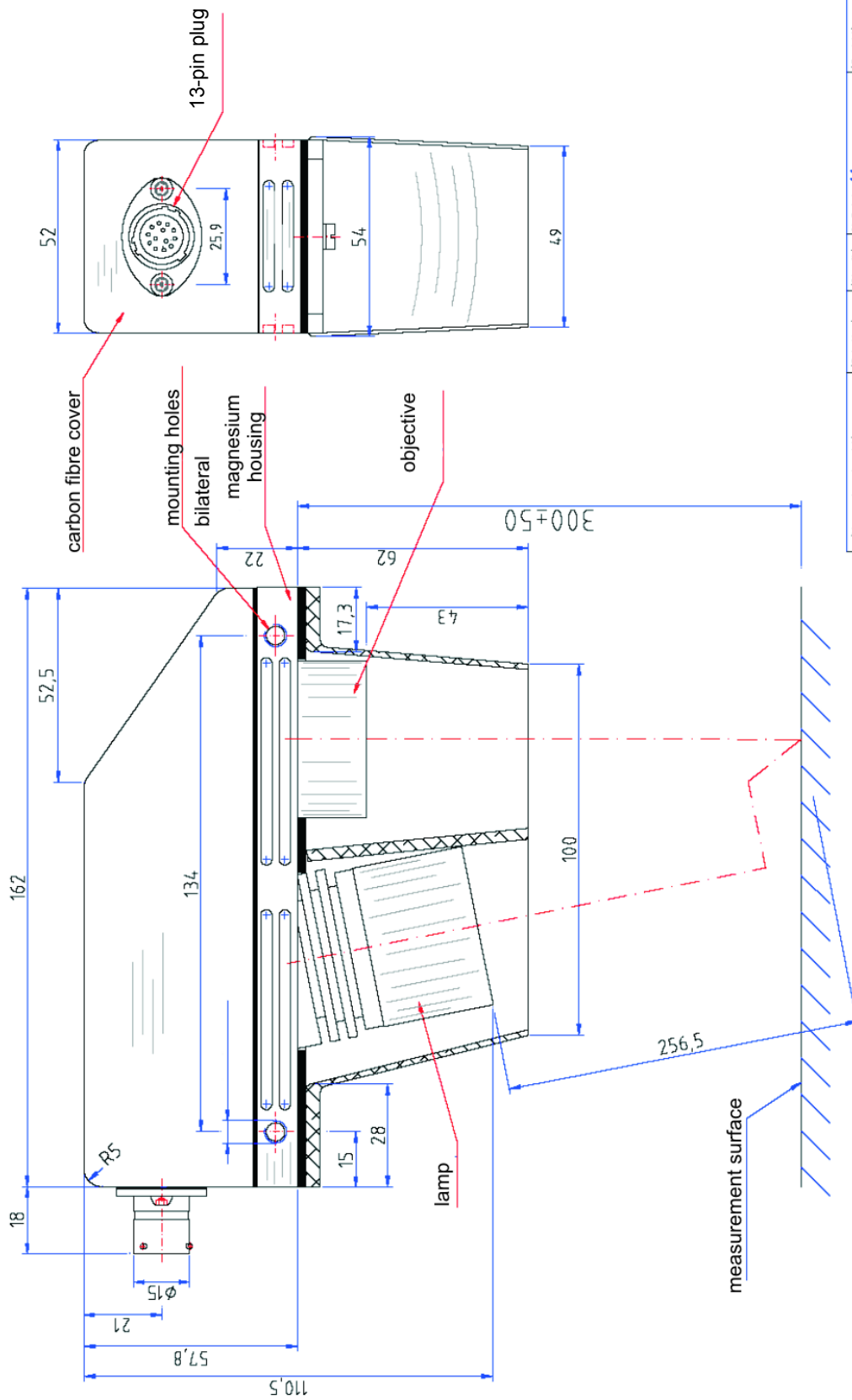

Verwendungsbereich AutoCAD LT 2000	(Zul. Abw.)	DIN 2768 fein	(Oberfl.)	M035-80-00-00	(Gewicht)	magnesium housing + carbon cover
	Bearb.	23.03.2002	Name	SL Racing Sensor Head		
	Gepr.	23.03.2002	Wegl.	M035-80-00-00		
	Norm		M.Schmidt	Blatt		
Zust.		Anderung	Datum	Name	Ursprung	
					Ersatz durch:	

